

BATCHING DEVICE TYPE DRE

1. Dial with scales
2. Reading Mark
3. Starter
4. Override latch
5. Ratchet screw
6. Pawl disc
7. Switch

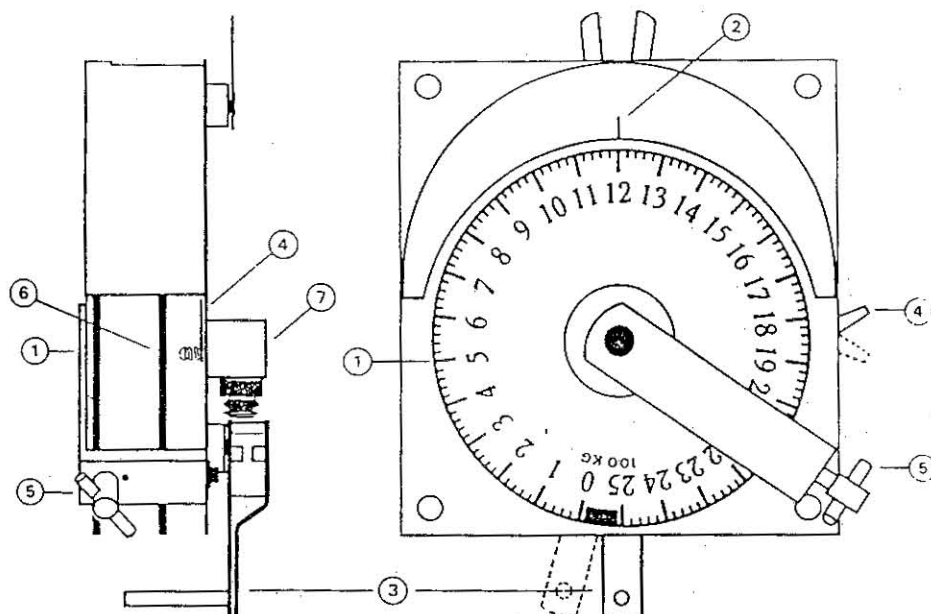

Batching device type DRE

- Can be mounted on weigher type 5 and 15.
- Can be combined with filling control device type FE.
- For units with electrically driven grain conveyor for grain supply.

Dial with scale

One dividing line indicates 2 tippings of 10 kg. Each figure on the scale indicates 100 kg material weighed out. (Please see remark below).

Adjustments

When the ratchet screw (5) is slackened the dial (1) can be turned in both directions within the limit of the scale. (Do not try to turn the dial past 0 or 25). The dividing line indicating the required quantity, is placed against the mark (2). If you want to weigh out e.g. 1,200 kg the figure 12 is placed against the mark. If you want to weigh out 280 kg, you set the 4th dividing line between 2 and 3. After adjustment of the required quantity, the dial is locked by means of the ratchet screw (5).

Starter

The starter (3) is moved to the left. In this position the mechanism is secured with switches on the micro switch (indicated by a click), while the starter itself can fall back in vertical position. During the weighing the pawl disc (6) is gradually moved forwards. When the required quantity is weighed out, the weighing is stopped and the pawl disc is moved by a spring back against the stop, the position of which is determined by the adjustment of the dial. When the starter is activated again, the weigher will repeat the weighing out of the quantity previously selected.

Distance control

The starter can be activated – if required – by a compressed-air cylinder.